

# Cuisinart® INSTRUCTION BOOKLET & RECIPES



**Griddler™ overstuffed sandwich maker**

**CGR-SMC**

For your safety and continued enjoyment of this product, always read the instruction book carefully before using.

IB-7639-CAN

---

## CONTENTS

Important Safeguards.....	2
Instructions for Use .....	3
Special Features .....	3
Tips and Hints.....	4
Cleaning and Maintenance.....	4
Storage.....	4
Warranty.....	5

## IMPORTANT SAFEGUARDS

When using an electrical appliance, basic safety precautions should always be followed, including the following:

1. READ ALL INSTRUCTIONS.
2. Do not touch hot surfaces. Use handles and knobs.
3. To protect against fire, electrical shock, and injury to persons, DO NOT IMMERSE CORD, plug, or unit in water or other liquids.
4. Close supervision is necessary when any appliance is used by or near children.
5. Unplug from outlet when not in use and before cleaning. Allow to cool before putting on or taking off parts, and before cleaning appliance.
6. Do not operate any appliance with a damaged cord or plug or after the appliance malfunctions or has been damaged in any manner. Return appliance to the nearest Customer Service centre see Warranty for details) for examination, repair, or adjustment.
7. The use of accessory attachments not recommended by Cuisinart may result in fire, electrical shock, or injury to persons.
8. Do not use outdoors.
9. Do not let power cord hang over edge of table or counter, or touch hot surfaces.
10. Do not place on or near a hot gas or electric burner, or in a heated oven.
11. Unplug the unit when finished cooking.

12. Do not use appliance for other than intended use.
13. Extreme caution must be used when moving an appliance containing hot oil or other hot liquids.
14. Always attach plug to appliance first, then plug cord into the wall outlet. To disconnect, remove plug from wall outlet.
15. WARNING: TO REDUCE THE RISK OF FIRE OR ELECTRIC SHOCK, REPAIR SHOULD BE DONE ONLY BY AUTHORIZED PERSONNEL. DO NOT REMOVE THE BASE PANEL. NO USER SERVICEABLE PARTS ARE INSIDE.

## SAVE THESE INSTRUCTIONS

## FOR HOUSEHOLD USE ONLY

## SPECIAL CORD SET INSTRUCTIONS

A short power-supply cord is to be provided to reduce the risks resulting from becoming entangled in or tripping over a longer cord.

Longer extension cords are available and may be used if care is exercised in their use.

If a long extension cord is used, the marked electrical rating of the extension cord should be at least as great as the electrical rating of the appliance, and the longer cord should be arranged so that it will not drape over the countertop or tabletop where it can be pulled on by children unintentionally, or tripped over.

## NOTICE

This appliance has a polarized plug (one blade is wider than the other). To reduce the risk of electric shock, this plug will fit in a polarized outlet only one way. If the plug does not fit fully in the outlet, reverse the plug. If it still does not fit, contact a qualified electrician. Do not modify the plug in any way.

# INSTRUCTIONS FOR USE

1. Before using your Cuisinart® Griddler™ overstuffed sandwich maker for the first time, remove all protective paper and wrapping. Remove any dust from shipping by wiping the plates with a damp cloth.
2. Preheat the sandwich maker. Close lid and plug cord into a 120V AC wall outlet. The red light will go on to signal power. The green indicator light will go on when unit is ready to use.

**Note:** The first time you use your sandwich maker, it may have a slight odour and may smoke a bit. This is normal, and common to appliances with a nonstick surface.

**Note:** The cooking plates of this Cuisinart® Griddler™ overstuffed sandwich maker have been treated with a special nonstick coating. Before the first use, we suggest you season the grids with cooking spray or oil. If using oil, apply with a paper towel or pastry brush. You may find it helpful to repeat this process before each use of the sandwich maker.

3. When the green indicator light goes on, place ingredients on bottom plate according to recipes. Close the lid and lock it.
4. It may take several seconds for the green light to go off. This is normal.
5. Once the food is ready to eat, the green light will come on again.
6. Remove food by gently loosening the edges with a heat-proof plastic spatula. Never use metal utensils, as they may damage the nonstick coating.
7. Always disconnect the plug from the wall outlet once cooking is completed.

## SPECIAL FEATURES

### 1. Indicator Lights

Red light illuminates when sandwich maker has power on.

Green light illuminates when sandwich maker is ready to cook.

Green light illuminates again when food is ready.

### 2. Lock Down Lid

Lock-on handle secures contents while cooking.

### 3. Rubber Feet

Will not mark countertop; keep unit steady.

### 4. Nonstick Plates

Removable and dishwasher safe.

### 5. Brushed Stainless Steel Housing Cover

### 6. Cord Storage (not shown)

Cord wraps under unit for easy storage.

### 7. Plate Release Button

Push in to release and remove cooking plates.

### 8. Temperature Control Knob

Low, Medium and High settings.

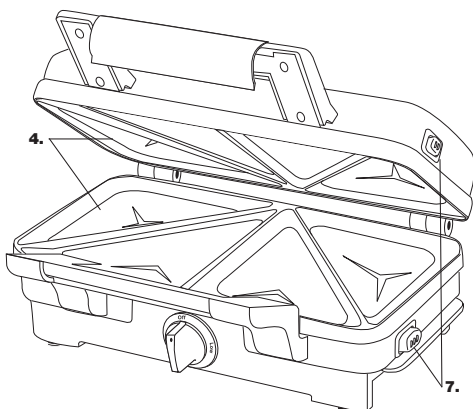
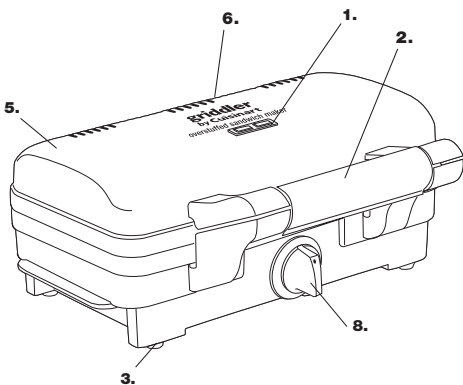

---

## Tips And Hints

Preheat your Cuisinart® Griddler™ overstuffed sandwich maker completely before using. For sandwiches that are quick to assemble, prepare sandwich fixings while grill is preheating. The lid to the sandwich maker should be closed while it is preheating as well as in between making batches of sandwiches.

The Cuisinart® Griddler™ overstuffed sandwich maker is designed to accommodate breads of all shapes and sizes. The sandwich plates measure 5½ x 5 inches (13.75 x 12.5 cm) to accommodate a wide variety of bread sizes. Breads that are longer than 5½ inches (13.75 cm) can easily be toasted lengthwise or on the diagonal. Breads can also be sliced from whole loaves.

Butter, margarine, and olive oil are recommended for coating the outside of bread when making sandwiches. “Light” versions of margarines are not recommended as they do not withstand heat (check manufacturer’s labels for cooking recommendations for best results).

Have butter or margarine at room temperature when spreading on bread, or melt and apply with a pastry brush.

For best results, moist ingredients such as sliced tomatoes or fruits, pickles, etc., should be blotted or patted dry with a paper towel. Sauces, such as tomato sauce or salsa, can be drained for a short time in a strainer lined with a coffee filter to remove excess liquid.

There are limitless filling options for the sandwich maker – from breakfast to snacks and from dinner to dessert. Try a wide variety of breakfast sandwiches, and omelets, mini pizzas and calzones, burritos and fruit pies.

Make tasty muffins and small cakes in your sandwich maker. Most muffin mixes bake best by using the setting between medium and high. Spray sandwich plates with cooking spray once preheated and use ¼ cup (50 ml) of batter per sandwich pocket.

Muffins bake between 6 and 9 minutes.

Packaged biscuits, bread and pizza doughs found in the refrigerated section make great sandwich “shells” for any type of filling.

## CLEANING AND MAINTENANCE

Once you have finished cooking in the sandwich maker, remove plug from electrical outlet. Leave top lid open so plates begin to cool.

Never take your sandwich maker apart for cleaning. Simply brush crumbs from grooves, and absorb any excess cooking oil or excess fillings by wiping with a dry cloth or paper towel.

You may clean the cooking plates by wiping with a damp cloth, or you may put them in the dishwasher. This will prevent staining or sticking from build up of oil or fillings. **Be certain plates have cooled completely before cleaning.** If food adheres to plates, simply pour a little cooking oil onto area and let stand approximately 5 minutes, thus allowing baked-on food to soften for easy removal.

To clean exterior, wipe with a soft dry cloth. Never use an abrasive cleanser or harsh pad. **Never immerse cord, plug or unit in water or other liquid. DO NOT PUT IN DISHWASHER.**

## STORAGE

Store with cord wrapped securely in the rear of the base. For compact storage, stand sandwich maker upright on back end. The sandwich maker has been designed with a special latch so lid stays closed during storage.

---

# WARRANTY

## LIMITED THREE-YEAR WARRANTY

This warranty supersedes all previous warranties on this Cuisinart® product. This warranty is available to consumers only. You are a consumer if you own a Cuisinart® product that was purchased at retail for personal, family or household use. This warranty is not available to retailers or other commercial purchasers or owners.

We warrant that this Cuisinart® product will be free of defects in material or workmanship under normal home use for three years from the date of original purchase.

For warranty purposes, we would like to suggest that you register your product on-line at [www.cuisinart.ca](http://www.cuisinart.ca) to facilitate verification of the date of original purchase. However, should you not wish to register on-line we recommend the consumer to maintain original receipt indicating proof of purchase. In the event that you do not have proof of purchase date, the purchase date for purposes of this warranty will be the date of manufacture.

When calling our Authorized Service Centre for in warranty service please make reference to your model number and the manufacturing date code. This information can be found in the rating area on the body or underneath the base of your unit. The model number will follow the word Model: CGR-SMC. The manufacturing date code is a 6 digit number. Example, 080630 would designate year, month & day (2008, June 30th).

If your Cuisinart® product should prove to be defective within the warranty period, we will repair it or, if we think it necessary, replace it. To obtain warranty service, please call our Consumer Service Centre toll-free at 1-800-472-7606 or write to:

Cuisinart Canada  
100 Conair Parkway,  
Woodbridge, Ontario L4H 0L2

To facilitate the speed and accuracy of your return, please also enclose \$10.00 for ship-

ping and handling of the product. Please also be sure to include a return address, description of the product defect, product serial number, and any other information pertinent to the product's return. Please pay by cheque or money order.

NOTE: For added protection and secure handling of any Cuisinart® product that is being returned, we recommend you use a traceable, insured delivery service.

Cuisinart cannot be held responsible for in transit damage or for packages that are not delivered to us. Lost and/or damaged products are not covered under warranty.

Your Cuisinart® product has been manufactured to strict specifications and has been designed for use with Cuisinart® authorized accessories and replacement parts for your model.

These warranties expressly exclude any defects or damages caused by accessories, replacement parts or repair service other than those that have been authorized by Cuisinart. These warranties exclude all incidental or consequential damages.

## BEFORE RETURNING YOUR CUISINART PRODUCT

Important: If the nonconforming product is to be serviced by someone other than Cuisinart's Authorized Service Centre, please remind the servicer to call our Consumer Service Centre to ensure that the problem is properly diagnosed, the product serviced with the correct parts, and to ensure that the product is still under warranty.

---

©2008 Cuisinart  
Cuisinart® is a registered  
trademark of Cuisinart

100 Conair Parkway  
Woodbridge, Ont L4H 0L2  
Consumer Call Centre Email:  
Consumer\_Canada@Conair.com  
1-800-472-7607  
Printed in China

08CC067

Any other trademarks or service marks of third parties referred to herein are the  
trademarks or service marks of their respective owners.

---

the  
**GRIDDLER™**  
overstuffed sandwich maker  
a guide to perfect meals



**Cuisinart®**



---

# SAVORY & SWEET RECIPES



## BREAKFAST

Individual Spinach and Goat Cheese Frittatas .....	9
Breakfast on the Go .....	10
French Toast.....	10

## THE MAIN COURSE

Grilled BLT with Provolone .....	11
Grilled Reubens .....	11
Grilled Sopressata with Fontina and Arugula .....	12
Toasted Prosciutto, Tomato and Fresh Mozzarella.....	12
Croque Monsieur .....	13
Grilled Smoked Turkey with Brie and Apples .....	14
The Gobbler .....	14
Toasted Avocado, Cheese and Tomato .....	15
Three-Cheese Calzones with Sausage and Pesto .....	16
Chicken and Green Chile Burritos with Black Beans .....	16

## DESSERTS

Caramelized Apple Turnovers.....	17
S'mores .....	18



---

# BREAKFAST

## Individual Spinach and Goat Cheese Frittatas

Just one of many delicious frittatas that you can make in your overstuffed sandwich maker!

Makes 4 individual frittatas

- ½**    **teaspoon (2 ml) olive oil**
- 1**    **garlic clove, smashed**
- 1**    **packed cup spinach leaves**
- 4**    **large eggs**
- 1**    **tablespoon (15 ml) whole milk**
- 2**    **tablespoons (30 ml) soft goat cheese or chèvre**
- 2**    **tablespoons (30 ml) grated Parmesan**
- 1**    **tablespoon (15 ml) fresh basil, thinly sliced**
- pinch kosher salt**
- pinch freshly ground pepper**

Place a small skillet over medium heat and add the olive oil. Once heated through, add the garlic and spinach. Stir together until spinach is wilted. Remove and reserve.

Whisk the eggs and milk together. Stir the cheeses in with the eggs. Fold in the reserved spinach and basil and season with the pinch of salt and pepper.

Preheat the Griddler™ overstuffed sandwich maker to medium. Once green indicator light is on, pour the egg mixture equally into each of the four pockets and close. Frittatas should be done between 5 and 6 minutes.

Remove and serve immediately.

*Nutritional information per frittata:*  
*Calories 110 (63% from fat) • carb. 1g • pro. 9g • fat 8g • sat. fat 3g*  
*• chol. 215mg • sod. 180mg • calc. 80mg • fiber 0g*



---

# Breakfast on the Go

Makes 2 sandwiches, or 4 servings

- 4 large eggs**
- cooking spray**
- 4 slices white or whole wheat bread**
- ¼ cup (50 ml) shredded Cheddar**
- 2 tablespoons (30 ml) melted butter**

Preheat the Griddler™ overstuffed sandwich maker to medium.

Whisk eggs together in a liquid measuring cup. Once green indicator light is on, spray the sandwich plates with cooking spray and pour eggs equally into the four pockets and close. Eggs will be cooked in about 5 minutes. Remove and reserve.

Turn the heat up to high.

Lay two slices of bread on a work surface. Divide eggs equally between the two slices of bread. Top each with 2 tablespoons (30 ml) of cheese. Place remaining bread on top of sandwiches and lightly brush tops with melted butter.

Once green indicator is on, place sandwiches in heated sandwich plates and close. Toast sandwiches for about 5 minutes, until bread is evenly golden and toasted.

Cut sandwiches along the perforated edge and serve.

*Nutritional information per serving:*  
*Calories 236 (49% from fat) • carb. 17g • pro. 13g • fat 13g • sat. fat 6g*  
*• chol. 230mg • sod. 354mg • calc. 154mg • fiber 1g*

## French Toast

Makes 2 servings

- 2 large eggs, lightly beaten**
- ½ cup (125 ml) whole milk, may use reduced-fat milk**
- ½ teaspoon (2 ml) pure vanilla extract**
- 4 thick slices challah bread**
- cooking spray**

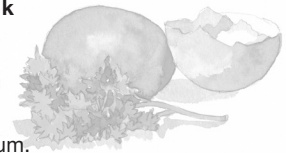

Preheat the Griddler™ overstuffed sandwich maker to medium.

Whisk together the eggs, milk, and vanilla in a small bowl. Place the bread slices in a 9 x 9-inch (22.5 x 22.5 cm) baking dish. Pour the egg mixture into the pan. Turn the bread slices to coat completely and let stand until the liquid is completely absorbed, about 5 minutes.

Once the green indicator is on, spray the sandwich plates lightly with cooking spray. Place two of the bread slices on the sandwich plates and close. Cook French toast for about 5 minutes. Repeat with remaining 2 slices.

Serve with butter and maple syrup or sprinkle with confectioners' sugar.

*Nutritional information per serving:*  
*Calories 363 (25% from fat) • carb. 50g • pro. 17g • fat 10g • sat. fat 3g*  
*• chol. 221mg • sod. 551mg • calc. 191mg • fiber 2g*

---

# THE MAIN COURSE

## Grilled BLT with Provolone

This upscale version is delicious with the added cheeses.

Makes 2 sandwiches

- 4 slices sourdough bread**
- 6 slices bacon, cooked**
- ½ cup (125 ml) arugula**
- 1 tomato, sliced**
- pinch kosher salt**
- pinch freshly ground pepper**
- 1½ ounces (45 g) provolone, sliced**
- 1 teaspoon (5 ml) mayonnaise**
- 1½ tablespoons (25 ml) unsalted butter, melted**



Preheat Griddler™ overstuffed sandwich maker to high.

Lay two slices of bread on a work surface. Place 3 slices of the cooked bacon on each. Top each with half of the arugula leaves and 2 slices of tomato. Sprinkle the tomatoes lightly with a pinch of salt and pepper and top each with one slice of provolone. Spread ½ teaspoon (2 ml) mayonnaise on top of the provolone. Place remaining bread on top of sandwiches and lightly brush tops with melted butter.

Once green indicator is on, place sandwiches in heated sandwich plates and close. Toast sandwiches for about 5 minutes, until bread is evenly golden and toasted.

Cut sandwiches along the perforated edge and serve.

*Nutritional information per sandwich:*

*Calories 470 (52% from fat) • carb. 36g • pro. 21g • fat 27g • sat. fat 13g  
• chol. 65mg • sod. 1230mg • calc. 225mg • fiber 3g*

## Grilled Reubens

Makes 2 sandwiches

- 4 slices rye bread**
- 2 ounces (60 g) corned beef, thinly sliced**
- 2 teaspoons (10 ml) Russian or Thousand Island dressing**
- ¼ cup (50 ml) sauerkraut, well drained**
- 1 ounce (30 g) Swiss cheese**
- 1 tablespoon (15 ml) unsalted butter, melted**

Preheat the Griddler™ overstuffed sandwich maker to high.

Lay two slices of rye bread on a work surface. Place 1 ounce (30 g) of corned beef on each slice of bread and spread 1 teaspoon (5 ml) of Russian dressing on each. Place 2 tablespoons (30 ml) of sauerkraut on each sandwich and top with Swiss cheese. Place remaining bread on top of sandwiches and lightly brush tops with melted butter.

---

Once green indicator is on, place sandwiches in heated sandwich plates and close. Toast sandwiches for about 5 minutes, until bread is evenly golden and toasted.

Cut sandwiches along the perforated edge and serve.

*Nutritional information per sandwich:*  
*Calories 360 (46% from fat) • carb. 34g • pro. 15g • fat 19g • sat. fat 9g*  
*• chol. 55mg • sod. 870mg • calc. 169mg • fiber 4g*

## Grilled Sopressata with Fontina and Arugula

Makes 2 sandwiches

- 4 slices sourdough bread, sliced**
- 2 ounces (60 g) sopressata, sliced**
- ½ ounce (15 g) fontina, sliced**
- ¼ cup (50 ml) arugula**
- 1 tablespoon (15 ml) olive oil**



Preheat the Griddler™ overstuffed sandwich maker to high.

Lay two slices of bread on a work surface. Place 1 ounce (30 g) sopressata on each slice of bread and top each evenly with the fontina cheese and arugula. Place remaining bread on top of sandwiches and lightly brush tops with olive oil.

Once green indicator is on, place sandwiches in heated sandwich plates and close. Toast sandwiches for about 5 minutes, until bread is evenly golden and toasted.

Cut sandwiches along the perforated edge and serve.

*Nutritional information per sandwich:*  
*Calories 370 (47% from fat) • carb. 34g • pro. 15g • fat 19g • sat. fat 6g*  
*• chol. 35mg • sod. 1010mg • calc. 94mg • fiber 2g*

## Toasted Prosciutto, Tomato, and Fresh Mozzarella

A delicious sandwich combination.

Makes 2 sandwiches

- 4 slices sourdough or ciabatta bread**
- 6 slices prosciutto**
- 4 slices tomato**
- 2 ounces (60 g) fresh mozzarella (approximately 2 to 3 slices per sandwich)**
- 4 basil leaves**
- 1 tablespoon (15 ml) olive oil**

Preheat the Griddler™ overstuffed sandwich maker to high.

---

Lay two slices of bread on a work surface. Place 3 slices of prosciutto on each slice of bread and top each with 2 slices of tomato. Distribute fresh mozzarella and basil leaves equally between the two sandwiches. Place remaining bread on top of sandwiches and lightly brush tops with olive oil.

Once green indicator is on, place sandwiches in heated sandwich plates and close. Toast sandwiches for about 5 minutes, until bread is evenly golden and toasted.

Cut sandwiches along the perforated edge and serve.

*Nutritional information per sandwich:*  
Calories 380 (44% from fat) • carb. 36g • pro. 17g • fat 18g • sat. fat 7g  
• chol. 40mg • sod. 900mg • calc. 222mg • fiber 2g

## Croque Monsieur

The taste of this French classic is hard to beat.

Makes 2 sandwiches

**4 slices hearty, country white bread**  
**8 ounces (240 g) sliced ham**  
**1 teaspoon (5 ml) Dijon mustard**  
**2 ounces (60 g) Gruyère cheese, thinly sliced**  
**1½ tablespoons (25 ml) unsalted butter, melted for brushing**

Preheat the Griddler™ overstuffed sandwich maker to high.

Lay two slices of bread on a work surface. Place 4 ounces (115 g) of ham on each slice of bread. Spread the ham with ½ teaspoon (2 ml) of mustard and place 1 ounce (30 g) of the sliced Gruyère on top of each. Place remaining bread on top of sandwiches and lightly brush tops with melted butter.

Once green indicator is on, place sandwiches in heated sandwich plates and close. Toast sandwiches for about 5 to 7 minutes, until bread is evenly golden and toasted.

Cut sandwiches along the perforated edge and serve.

*Nutritional information per sandwich:*  
Calories 457 (41% from fat) • carb. 34g • pro. 33g • fat 21g • sat. fat 10g  
• chol. 100mg • sod. 1890mg • calc. 350mg • fiber 2g



---

# Grilled Smoked Turkey with Brie and Apples

These ingredients create a great flavour combination.

Makes 2 sandwiches

- 4 slices multigrain bread**
- 4 ounces (115 g) smoked turkey, sliced**
- ½ teaspoon (2 ml) grainy mustard**
- 1 ounce (30 g) Brie, sliced and chilled**
- 8 thin slices green apple**
- 1 tablespoon (15 ml) unsalted butter, melted**

Preheat the Griddler™ overstuffed sandwich maker to high.

Lay two slices of bread on a work surface. Place 2 ounces (60 g) of turkey on each slice of bread and top each evenly with the mustard. Place cold Brie and apple slices evenly between the two sandwiches. Place remaining bread on top of sandwiches and lightly brush tops with melted butter.

Once green indicator is on, place sandwiches in heated sandwich plates and close. Toast sandwiches for about 5 minutes, until bread is evenly golden and toasted.

Cut sandwiches along the perforated edge and serve.

*Nutritional information per sandwich:*  
*Calories 290 (37% from fat) • carb. 27g • pro. 19g • fat 12g • sat. fat 7g*  
*• chol. 55mg • sod. 1040mg • calc. 85mg • fiber 4g*

## The Gobbler

The Thanksgiving leftover sandwich –  
so good you will want to prepare it anytime!

Makes 2 sandwiches

- 4 slices white bread**
- 5 ounces (145 g) sliced turkey**
- 1 teaspoon (5 ml) mayonnaise**
- ¼ cup (50 ml) prepared bread stuffing**
- 1 tablespoon (15 ml) plus 1 teaspoon (5 ml) cranberry sauce**
- 1 tablespoon (15 ml) unsalted butter, melted**

Preheat the Griddler™ overstuffed sandwich maker to high.

Lay two slices of bread on a work surface. Place 2½ ounces (70 g) of turkey on each slice of bread and top each with ½ teaspoon (2 ml) of mayonnaise and 2 tablespoons (30 ml) of stuffing. Top each sandwich evenly with cranberry sauce. Place remaining bread on top of sandwiches and lightly brush tops with melted butter.

Once green indicator is on, place sandwiches in heated sandwich plates and close. Toast sandwiches for about 4 to 5 minutes, until bread is evenly golden and toasted.

Cut sandwiches along the perforated edge and serve.

*Nutritional information per sandwich:*  
*Calories 550 (23% from fat) • carb. 80g • pro. 24g • fat 14g • sat. fat 5g*  
*• chol. 45mg • sod. 1670mg • calc. 113 mg • fiber 5g*

---

# Toasted Avocado, Cheese, and Tomato

So simple but so delicious!

Makes 2 sandwiches

- 4 slices multigrain bread**
- ½ avocado, sliced**
- 4 slices tomato**
- 1 ounce (30 g) sliced Cheddar**
- ¼ teaspoon (1 ml) kosher salt**
- ¼ teaspoon (1 ml) freshly ground pepper**
- 1½ tablespoons (25 ml) unsalted butter, melted**

Preheat the Griddler™ overstuffed sandwich maker to high.

Lay two slices of bread on a work surface. Place avocado slices evenly on each slice of bread, and sprinkle with a pinch of the salt and pepper. Top each with 2 slices of tomato and sprinkle again with the remaining salt and pepper. Top each with equal amounts of the Cheddar. Place remaining bread on top of sandwiches and lightly brush tops with melted butter.

Once green indicator is on, place sandwiches in heated sandwich plates and close. Toast sandwiches for about 5 minutes, until bread is evenly golden and toasted.

Cut sandwiches along the perforated edge and serve.

*Nutritional information per sandwich:*

*Calories 330 (52% from fat) • carb. 30g • pro. 10g • fat 20g • sat. fat 8g  
• chol. 30mg • sod. 640mg • calc. 161mg • fiber 7g*





---

# Three-Cheese Calzones with Sausage and Pesto

Makes 8 calzones

- ½**    **teaspoon (2 ml) olive oil**
- 6**    **ounces (170 g) fresh Italian sausage (hot or sweet), casings removed**
- 2**    **garlic cloves, smashed and peeled**
- ¾**    **cup (175 ml) ricotta**
- ¾**    **cup (175 ml) shredded mozzarella**
- 3**    **tablespoons (45 ml) grated Parmesan**
- 2**    **teaspoons (10 ml) prepared pesto**
- 1**    **refrigerated package [13.8 ounces (410 g) ] pizza dough**

Place olive oil in a medium skillet over medium heat. Add sausage meat and smashed garlic cloves, and cook until meat is completely cooked through. Remove sausage. Reserve, and cool to room temperature.

While sausage is cooking, stir together the three cheeses and pesto. Stir in cooked sausage once cooked and slightly cooled.

Roll pizza dough into four long rectangles that are 5 x 10 inches (12.5 x 25 cm). Spread approximately ½ cup (125 ml) of calzone filling evenly on the bottom half of each rectangle. Fold the top part of the pizza dough down to cover the filling, and seal the calzones by pressing the dough together with fingers or fork to create a sealed 5 x 5-inch (12.5 x 12.5 cm) pocket.

Preheat the Griddler™ overstuffed sandwich maker to high. When green indicator lights, place two calzones into preheated sandwich plates. Close unit and bake for about 8 to 10 minutes, until pizza dough is evenly golden. Bake the remaining two calzones.

Cut into individual calzones along the perforated edges. Serve with warm marinara sauce.

*Nutritional information per calzone:*

*Calories 240 (35% from fat) • carb. 24g • pro. 14g • fat 9g • sat. fat 5g  
• chol. 30mg • sod. 540mg • calc. 128mg • fiber 0g*

# Chicken and Green Chile Burritos with Black Beans

A great but quick dinner idea to make use of leftovers and staple pantry items.

Makes 8 individual burritos

- 1**    **cup (250 ml) cooked chicken breast, cut into ½" (1.25 cm) cubes**
- 2**    **green onions, chopped**
- 1**    **can [15.5 ounces (460 g) ] black beans, rinsed and drained well**
- 1**    **can [14.5 ounces (430 g) ] chopped green chiles**
- pinch kosher salt**
- pinch freshly ground pepper**
- ½**    **cup (125 ml) shredded Cheddar**
- 4**    **10-inch (25 cm) flour tortillas**

---

In a small bowl combine chicken breast, green onions, black beans, green chiles, salt and pepper.

Preheat the Griddler™ overstuffed sandwich maker to high.

Place the tortillas on a work surface. Place ½ cup (125 ml) of chicken mixture in the centre of each tortilla and top each with 2 tablespoons (30 ml) of the shredded cheese. Roll burritos by folding the bottom of the tortilla over the filling. Fold in both sides of the tortilla and then roll up burrito. The burrito should be about 5 inches (12.5 cm) long.

Once green indicator is on, place burritos in heated sandwich plates lengthwise and close. Toast burritos for about 5 to 7 minutes, until tortilla is evenly golden and toasted.

Cut burrito pockets along the perforated edges and serve with guacamole, salsa, and sour cream on the side.

*Nutritional information per burrito:*  
Calories 200 (27% from fat) • carb. 24g • pro. 12g • fat 6g • sat. fat 3g  
• chol. 20mg • sod. 510mg • calc. 111mg • fiber 3g

## DESSERT

### Caramelized Apple Turnovers

A delicious and elegant dessert that is so easy to make.

Makes 8 turnovers

- 1½    tablespoons (25 ml) unsalted butter**
- 2       medium apples, peeled, cored, halved, and thinly sliced**
- 3       tablespoons (45 ml) granulated sugar**
- ½       teaspoon (2 ml) ground cinnamon**
- 1       pound (454 g) or 2 sheets packaged puff pastry, thawed**  
**melted butter for brushing**

Melt butter in a large skillet over medium heat. Add sliced apples, sugar, and cinnamon. Turn heat down to medium-low and cook apples, stirring occasionally, until soft and slightly caramelized, about 8 to 10 minutes. Remove and reserve.

On a floured work surface, roll each sheet of pastry into a large square. Cut each sheet of rolled pastry so that there are four 5 x 10-inch (12.5 x 25 cm) rectangles (two rectangles per pastry sheet). Place approximately ½ cup (125 ml) of apple on the bottom half of each pastry rectangle. Fold the top part of the pastry down to cover the apples, and close the turnovers by pressing fork tines around the pastry edge to create a sealed 5 x 5-inch (12.5 x 12.5 cm) pocket. Brush the tops of each pocket with melted butter.

Preheat the Griddler™ overstuffed sandwich maker to high. When green indicator lights, place two apple turnovers into preheated sandwich plates. Close unit and bake for about 8 to 10 minutes, until pastry is evenly golden. Bake the remaining two turnovers.

Cut into individual turnovers along the perforated edge. Top turnovers with vanilla ice cream and/or fresh whipped cream.

*Nutritional information per turnover:*  
Calories 370 (58% from fat) • carb. 34g • pro. 4g • fat 24g • sat. fat 7g  
• chol. 5mg • sod. 140mg • calc. 10mg • fiber 1g

---

# S'mores

This campfire classic is a big hit with kids of all ages.

Makes 2 sandwiches

- 4 slices challah or white bread**
- 1½ ounce (43 g) semisweet chocolate bar**
- ¼ cup (50 ml) mini marshmallows**
- 2 tablespoons (30 ml) unsalted butter, melted**

Preheat the Griddler™ overstuffed sandwich maker to high.

Lay two slices of bread on a work surface. Distribute chocolate and marshmallows equally between the 2 slices of bread. Place remaining bread on top of sandwiches and brush tops with melted butter.

Once green indicator is on, place sandwiches in heated sandwich plates and close. Toast sandwiches for about 5 minutes, until bread is evenly golden and toasted.

Cut sandwiches along the perforated edge and serve.

*Nutritional information per sandwich:*

*Calories 470 (41% from fat) • carb. 63g • pro. 9g • fat 23g • sat. fat 12g  
• chol. 75mg • sod. 410mg • calc. 85mg • fiber 3g*

